

SOT-25



Pin Definition:

1. Ground
2. Input
3. Enable
4. N/C
5. Output

General Description

The TS9010 series is combine high accuracy with very low power consumption, providing high output current even when the application requires very low dropout voltage. The Chip Enable (CE) includes a CMOS or TTL compatible input allows the output to be turned off to prolong battery life. The TS9010 series is included a precision voltage reference, error correction circuit, a current limited output driver and over temperature shutdown. This series are offered in 5-pin SOT-25 package.

Features

- Dropout voltage typically 0.4V @Io=150mA (Vo=5V)
- Output current up to 150mA (Vout=3V)
- Low power consumption
- Output voltage $\pm 2\%$
- Internal current limit
- Thermal shutdown protection

Applications

- Palmtops
- Video recorders
- Battery powered equipment
- PC peripherals
- High-efficiency linear power supplies
- Digital signal camera

Block Diagram

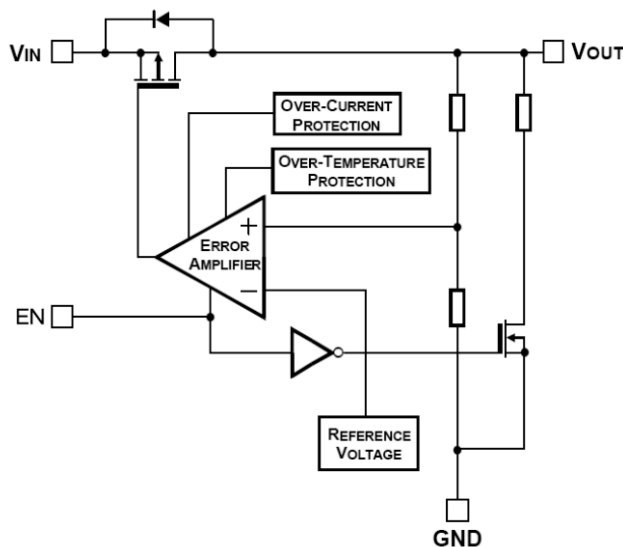

Ordering Information

Part No.	Package	Packing
TS9010 \underline{x} CX5 RF	SOT-25	3Kpcs / 7" Reel

Note: Where \underline{x} denotes voltage option, available are

- A= 1.5V
- D= 1.8V,
- K= 2.5V,
- S= 3.3V,
- 5= 5.0V.

Contact factory for additional voltage options.

Typical Application Circuit

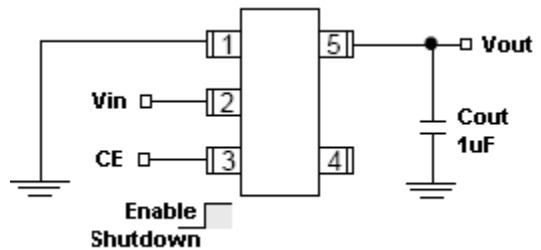

CE (pin 3) may be connected directly to Vin (pin 2)

Absolute Maximum Rating (Note 1)

Parameter	Symbol	Limit	Unit
Input Supply Voltage	V _{in}	+12	V
Enable Input Voltage	V _{ce}	0 ~ V _{in} +0.3	V
Output Current	I _o	200	mA
Power Dissipation (Note 3)	P _D	380	mW
Thermal Resistance	Θ _{ja}	220	°C/W
Operating Junction Temperature Range	T _j	-40 ~ +125	°C
Storage Temperature Range	T _{STG}	-65 ~ +150	°C
Lead Soldering Temperature (260°C)		5	S

Recommend Operating Rating (Note 2)

Input Supply Voltage	V _{in}	+10	V
Enable Input Voltage	V _{ce}	Gnd-0.3 ~ V _{in} +0.3	V

Electrical Characteristics (T_a = 25°C, C_{out}=2.2uF, V_{ce}2V, unless otherwise noted.)

Parameter	Conditions		Min	Typ	Max	Unit
Output Voltage	V _{in} =V _o + 1V, I _o = 40mA		0.98 V _o		1.02 V _o	V
Output Voltage Temperature Coefficient (Note 4)			--	100	--	ppm/°C
Line Regulation	V _o +1V ≤ V _{in} ≤ V _o +2V, I _o =1mA		--	0.2	0.3	%/V
Load Regulation (Note 5)	V _{in} =V _o +1V, 1mA ≤ I _L ≤ 150mA	V _o ≥ 2.5V	--	30	80	mV
	V _{in} =V _o +1V, 1mA ≤ I _L ≤ 80mA	V _o < 2.5V	--	40	90	
Dropout Voltage (Note 6)	I _o =80mA		--	200	400	mV
	I _o =150mA		--	400	700	
Quiescent Current	V _{in} ≤ 0.4V (shutdown)		--	0.01	1	uA
Ground Pin Current (Note 7)	V _{in} =V _{en} =V _o +1V		--	--	19	uA
	V _{in} =V _o +1V, V _{en} =Gnd		--	--	0.1	
Output Current Limit	V _{out} =0V		--	300	--	mA
Power Supply Rejection Ratio	At f=100Hz, I _o =0.1mA,		--	45	--	dB
Thermal Regulation (Note 8)			--	0.05	--	%/W

Electrical Characteristics (continued)

Parameter	Conditions	Min	Typ	Max	Unit
Enable Input					
Enable Input Logic-Low Voltage	Regulation shutdown	--	--	0.25	V
Enable Input Logic-High Voltage	Regulation enable	1.5	--	--	V
Enable Input Current	Vce=Vin	--	--	1	uA
	Vce=Gnd	0.2	0.05	0	

Notes:

- a. Exceeding the absolute maximum rating may damage the device.
- b. The device is not guaranteed to function outside its operating rating.
- c. The maximum allowable power dissipation at any Ta is $P_d(\max) = [T_j(\max) - T_a] * \theta_{ja}$. Exceeding the maximum allowable power dissipation will result in excessive die temperature, and the regulator will go into thermal shutdown.
- d. Output voltage temperature coefficient is defined as the worst case voltage change divided by the total temperature range.
- e. Regulation is measured at constant junction temperature using low duty cycle pulse testing. Parts are tested for load regulation in the load range from 1mA to 150mA ($V_{out} > 2.5V$) and 1mA to 80mA ($V_{out} < 2.5V$). Changes in output voltage due to heating effects are covered by the thermal regulation specification.
- f. Dropout voltage is defined as the input to output differential at which the output voltage drops 2% below its nominal value measured at 1V differential.
- g. Ground pin current is the regulator quiescent current plus pass transistor base current. The total current drawn from the supply is the sum of the load current plus the ground pin current.
- h. Thermal regulation is defined as the change in output voltage at a time "t" after a change in power dissipation is applied, excluding load or line regulation effects. Specifications are for a 150mA load pulse at $V_{in} = 12V$ for $t = 10ms$.

Application Examples

Standard Circuit

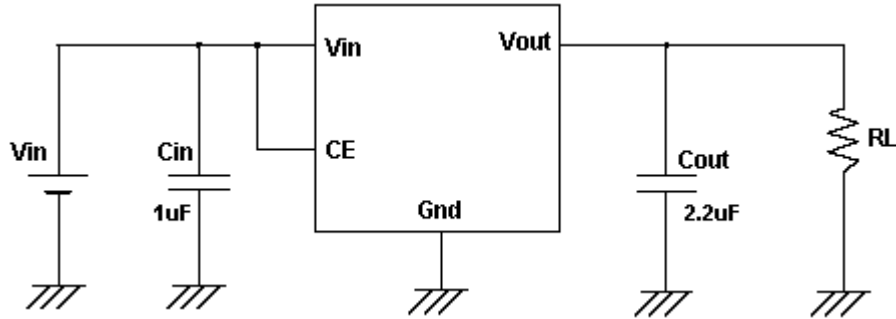

Typical Application Circuit 2

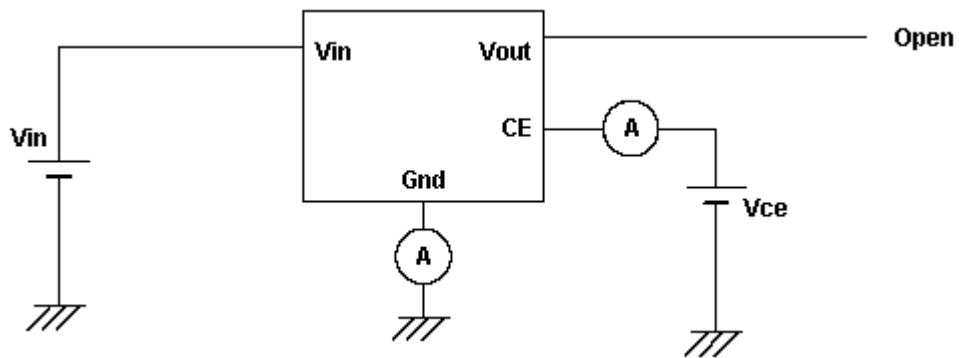

SOT-25 Mechanical Drawing

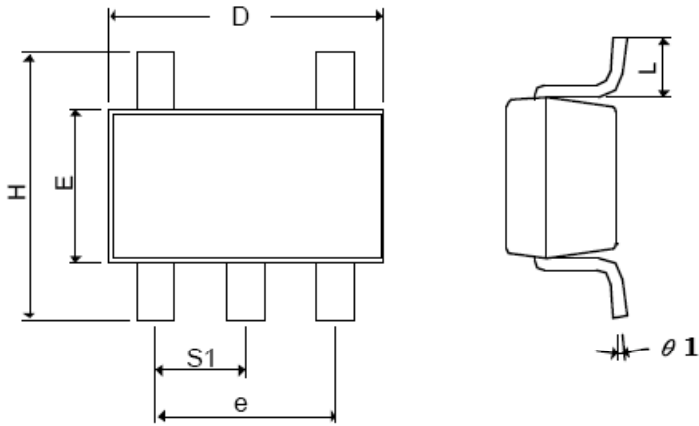

SOT-25 DIMENSION				
DIM	MILLIMETERS		INCHES	
	MIN	MAX	MIN	MAX.
A+A1	0.09	1.25	0.0354	0.0492
B	0.30	0.50	0.0118	0.0197
C	0.09	0.25	0.0035	0.0098
D	2.70	3.10	0.1063	0.1220
E	1.40	1.80	0.0551	0.0709
E	1.90 BSC		0.0748 BSC	
H	2.40	3.00	0.09449	0.1181
L	0.35 BSC		0.0138 BSC	
θ1	0°	10°	0°	10°
S1	0.95 BSC		0.0374 BSC	

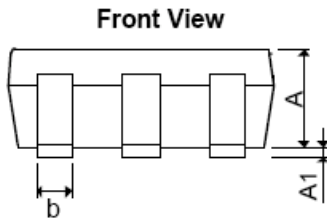

TS9010 Series

150mA CMOS LDO with Enable

Notice

Specifications of the products displayed herein are subject to change without notice. TSC or anyone on its behalf, assumes no responsibility or liability for any errors or inaccuracies.

Information contained herein is intended to provide a product description only. No license, express or implied, to any intellectual property rights is granted by this document. Except as provided in TSC's terms and conditions of sale for such products, TSC assumes no liability whatsoever, and disclaims any express or implied warranty, relating to sale and/or use of TSC products including liability or warranties relating to fitness for a particular purpose, merchantability, or infringement of any patent, copyright, or other intellectual property right.

The products shown herein are not designed for use in medical, life-saving, or life-sustaining applications. Customers using or selling these products for use in such applications do so at their own risk and agree to fully indemnify TSC for any damages resulting from such improper use or sale.